



ADVANCING  
SUSTAINABILITY  
TOGETHER

# XP

## Profiled Plate Valve

For your process gas applications

  
**HOERBIGER**

# The best valves in efficiency without sacrificing reliability and uptime

Conventional valve designs have outlived their purpose when it comes to increasing the efficiency and uptime of compressors. Real increases in compressor efficiency can only be achieved through innovative designs. The compressor valve is the heart of the compressor, and significantly determines the overall compressor efficiency and uptime. To optimize reliability and saving energy, you need a technologically advanced valve that can do both. HOERBIGER's XP Profiled Plate Valve combines all the properties to meet these requirements: The XP valves offer up to 50% higher effective flow area than conventional valves. The high performance PowerPEEK® valve plates outperform any other PEEK valve plates in terms for impact resistance and strength.

Further, you can drastically decrease the electric power and fuel consumption and reduce the related CO<sub>2</sub> emissions when increasing the service life and valve efficiency up to 50% in parallel. But not only that. The valves are also designed for applications in the field of green hydrogen production and hydrogen transport.

## Profiled plate/seat

- Streamlined flow path optimizes the effective flow area
- High number of flow channel
- Minimizes power consumption
- Aerodynamic flow path reduces build up of particles and provides higher tolerance of liquids

## Spring technology

- Heavy duty ESR wire springs
- Design reduces coil to coil contact
- Spring savers prevent coil to guard contact

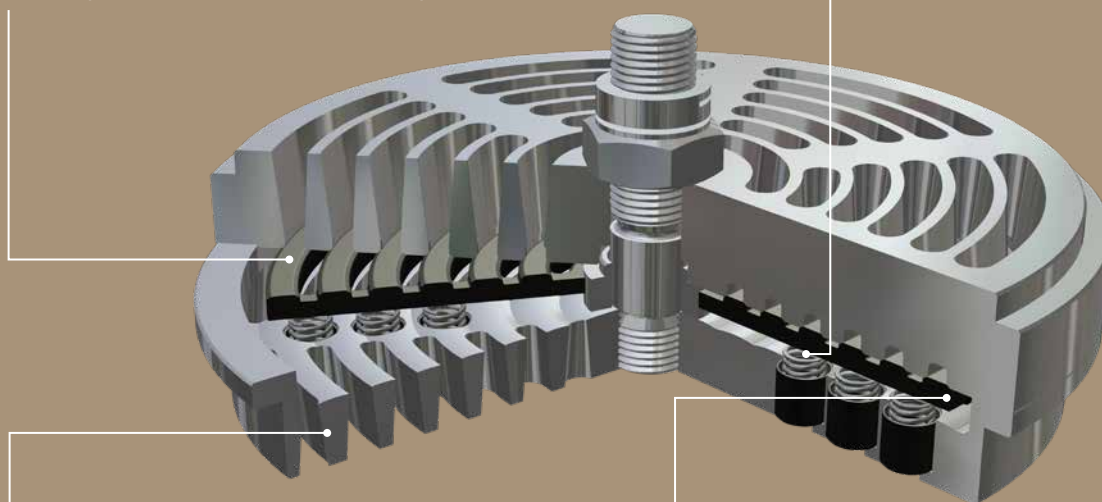
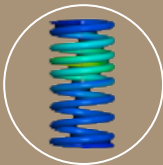

## Anti-stiction design

- Waveshape profiled guard and tapered seat
- Reduces adhesion forces due to liquids
- Avoids delays in valve opening and closing
- Tolerance against over-lubrication or liquid carry over

## PowerPEEK® valve plate

- Same thermal expansion as steel
- Injection molding leads to optimum fiber orientation and high flexural strength
- Excellent chemical resistance
- 4-6 time higher impact resistance than standard PEEK



# PowerPEEK®: High-performance valve plate material means

## High efficiency and long life

PowerPEEK® and the unique design of profiled valve plates create a valve with extreme efficiency and excellent flow characteristics. This automatically improves the valve's reliability and durability. The construction of a finer-meshed ring section increases the effective flow area and hence the efficiency of the valve. The aerodynamic design generates a lower pressure drop than conventional valve sealing elements and gives small amounts of liquid and debris the ability to pass through. PowerPEEK® plates also provide an optimized orientation of reinforcing fibers for extreme strength and robustness. This leads to an increase in MTBF and MTBM and higher production output.



## Your benefits at a glance

Features	Advantages	Benefits
Profiled plate design and higher number of flow channels	Industry benchmark in efficiency: 30 - 50% higher effective flow area than conventional valves. Superior efficiency even at low lift	Long life and high compressor uptime, reduced electric power/fuel consumption and related CO <sub>2</sub> emissions
Spring savers prevent coil to guard contact	Tribological optimization	
Injection molded high-performance PEEK®	Optimum fibre orientation and high flexural strength. 4-6 time higher impact resistance than standard PEEK	Excellent reliability for reduced downtimes, reduced maintenance costs and less emissions due to fewer on-site interventions
Aerodynamic flow path	Reduces build up of particles and provides tolerance of liquids	
Anti-stiction design: Waveshape profiled guard and tapered seat	Reduces adhesion forces due to liquids. Avoids delays in valve opening and closing. Tolerance against over-lubrication or liquid carry over	
Heavy duty springs made of ESR steel (Electro slag remelting)	Designed for high dynamic loads	
Outstanding effective flow area	Replace wear parts less frequently (longer service intervals)	Lower total cost of ownership Savings in CO <sub>2</sub> emissions and costs
High performance valve plate	Reduce main motor energy costs	
Tribological optimization	New built: reduce size, number of valves and compressor footprint	

# Need an appointment? Fill in the form or contact your sales representative.

First name \*

Last name \*

Email \*

Company \*

Country \*

Message

## \* GDPR Agreement

I consent to the transfer of this contact form and the storage of my personal information so that HOERBIGER can respond to my request.

See our [privacy policy](#) to learn more about how we use data.

**SUBMIT**

Send the form or your questions to: [c-globalmarketing@hoerbiger.com](mailto:c-globalmarketing@hoerbiger.com)



Scan for technical data  
and more information!

HOERBIGER is active throughout the world in the energy sector, the process industry, the automotive industry, the mechanical engineering sector, in safety engineering, and in the electrical industry. In 2021, its 5,862 employees achieved sales of 1.119 billion euros in 131 locations across 46 countries. Our products and services are used in reciprocating compressors, gas flow control units, vehicle drives, rotating unions, explosion protection, gas-powered engines, and in automobile hydraulics.

[HOERBIGER.COM](https://www.hoerbiger.com)

All rights reserved. Subject to change without notice © Copyright HOERBIGER 2023

  
**HOERBIGER**